

M7284C,Q Enhanced Modutrol IV Motors

The M7284 Enhanced Modutrol IV Motors are used to control dampers and valves. The motors accept a 4 to 20 mA current signal from an electronic controller to position a damper or valve at any point between open and closed.

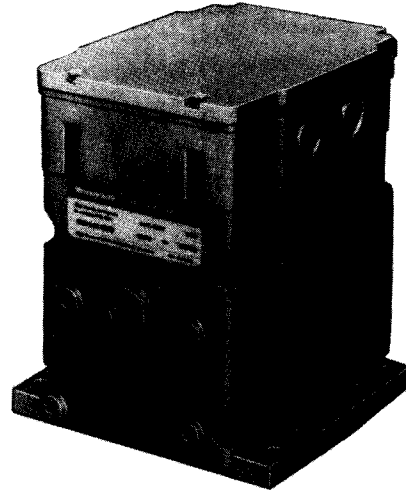

- Replaces M744T,Y Motors.
- M7284 is a non-spring return motor.
- Oil immersed motor and gear train for reliable performance and long life.
- Wiring box provides NEMA 3 weather protection when mounted in upright position.
- Actuator motor and circuitry operate from 24 Vac.
- Screw terminals standard.
- Adapter bracket for matching shaft height of older motors is standard with replacement motors.
- Nominal timing of 30 seconds for 90° stroke and 60 seconds for 160° stroke.
- Valve and damper linkages, explosion proof housing and auxiliary switches available as accessories.
- Non-spring return motors are rated for 150 lb-in. torque.
- Models available with adjustable zero and span.
- Models available with 4 to 20 mA input signal.
- Die-cast magnesium housing.

CONTENTS

<i>Specifications</i>	<i>2</i>
<i>Ordering Information</i>	<i>2</i>
<i>Installation</i>	<i>4</i>
<i>Settings and Adjustments</i>	<i>7</i>
<i>Operation and Checkout</i>	<i>9</i>

Specifications

IMPORTANT: The specifications given in this publication do not include normal manufacturing tolerances. Therefore, an individual unit may not exactly match the listed specifications. Also, this product is tested and calibrated under closely controlled conditions and some minor differences in performance can be expected if those conditions are changed.

MODELS:

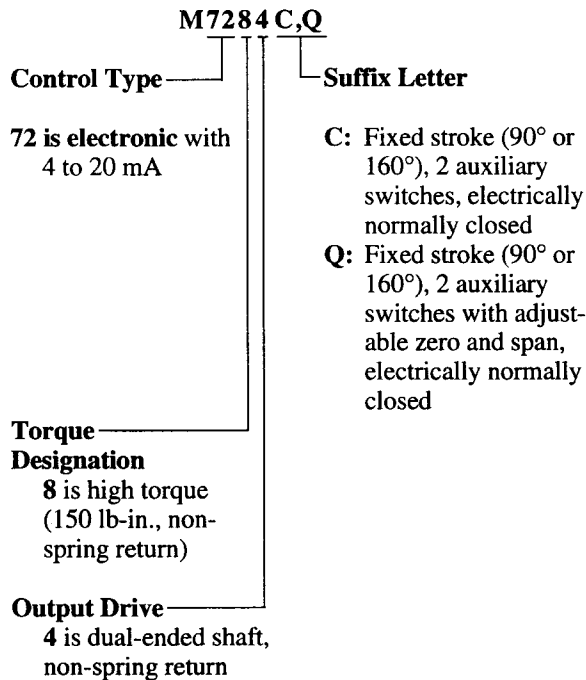

CONTROLLER: These motors can be used with any electronic controller that provides a stable noise-free proportional current output as specified in Input Range section.

MOTOR ROTATION: Normally closed. The closed position is the limit of the counterclockwise rotation as viewed from the power end of the motor. Non-spring return motors will rotate to the closed position on minimum input.

STROKE: Fixed 90° or 160° models available.

TIMING: Nominal 30 seconds for 90° stroke and 60 seconds for 160° stroke.

DEAD WEIGHT LOAD ON SHAFT: 200 lb [90.8 kg] on Power or Auxiliary End of motor; maximum combined load of 300 lb [134.6 kg].

AMBIENT TEMPERATURE RATINGS: -40° F to +150° F [-40° C to +66° C].

SHAFT: 3/8 in. [9.5 mm] square.

DIMENSIONS: See Fig. 1.

UNDERWRITERS LABORATORIES INC. LISTED: File no. E4436, Guide no. XAPX.

CANADIAN STANDARDS ASSOCIATION CERTIFIED: General listed File No. LR1620, Guide No. 400-E.

ELECTRICAL RATINGS:

Voltage and Frequency: 24 Vac, 50/60 Hz, includes isolation transformer.

Power: M7284C,Q: 23W, 0.24A

INPUT RANGE:

Current, Non-adjustable: 4 to 20 mA nominal, 25 mA maximum.

Current, Adjustable: 4 to 20 mA adjustable, 50 mA maximum.

Zero/Null (Motor Closed): 0.08 to 18 mA.

Span: 1.8 to 18 mA.

INPUT IMPEDANCE: 4 to 20 mA Input: 100 ohms.

Ordering Information

When purchasing replacement and modernization products from your wholesaler or distributor, refer to the price sheets for complete ordering number.

If you have additional questions, need further information, or would like to comment on our products or services, please write or phone:

1. Your local Honeywell Home and Building Control Sales Office (check white pages of your phone directory).
2. Home and Building Control Customer Satisfaction
Honeywell Inc., 1885 Douglas Drive North
Minneapolis, Minnesota 55422-4386 (612) 951-1000

In Canada—Honeywell Limited/Limitée, 740 Ellesmere Road, Scarborough, Ontario M1P 2V9. International Sales and Service offices in all principal cities of the world.

Fig. 1—Dimensions of M7284 Enhanced Modutrol IV Motors in in. [mm].

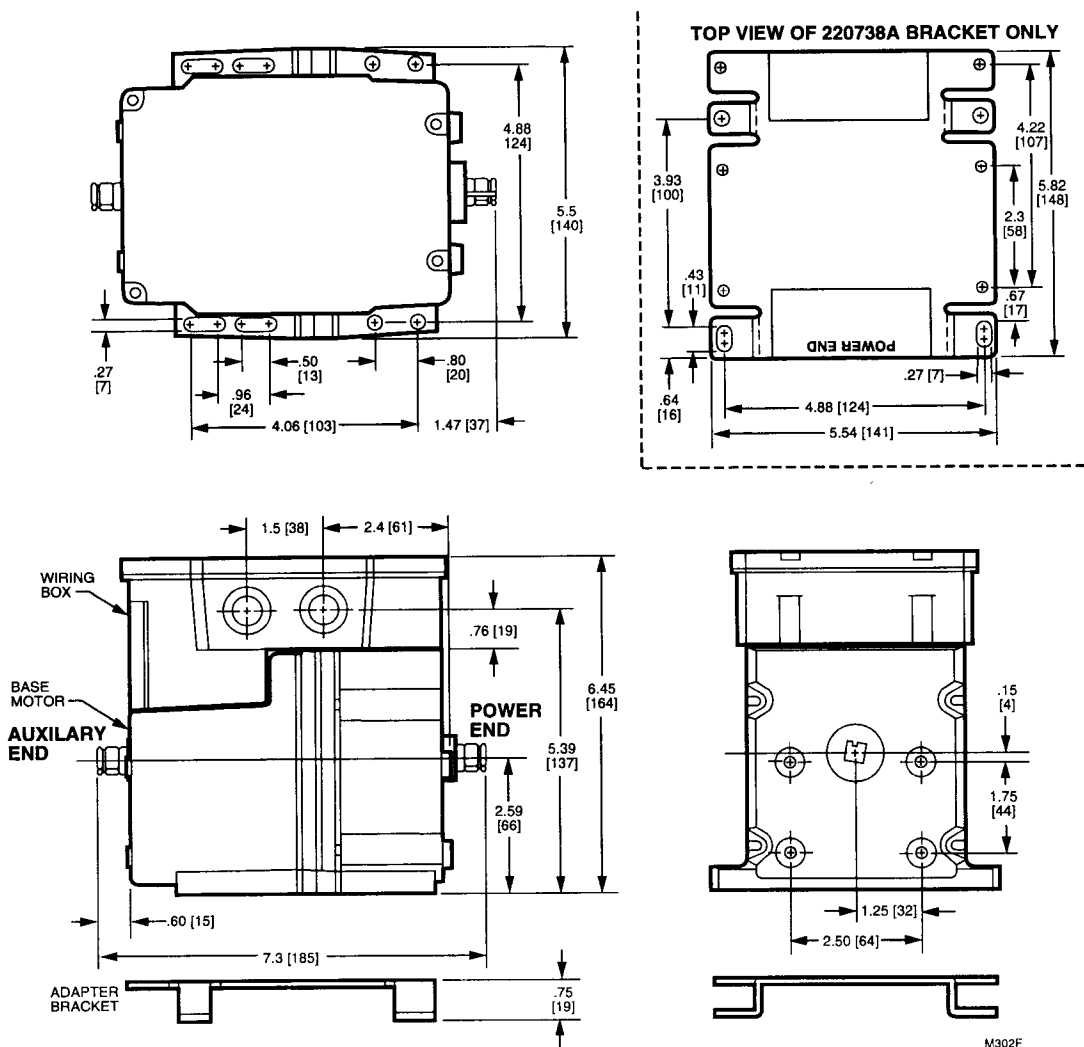

AUXILIARY SWITCH RATINGS (Amperes):

One Contact Rating ^a	120V	240V
Full Load	7.2	3.6
Locked Rotor	43.2	21.6

^a 40 VA pilot duty, 120/240 Vac on opposite contact.

ACCESSORIES:

- ES650117 Explosion-proof Housing: Encloses motor for use in explosive atmospheres. Not for use with Q601, Q618, and Q455 Linkages. Ordered separately from Nelson Electric Co. Requires Honeywell 7616DM Coupling.
- Q607 External Auxiliary Switch: Controls auxiliary equipment as a function of motor position.
- Q605 Damper Linkage: Connects motor to damper; includes motor crank arm.
- Q618 Linkage: Connects Modutrol IV Motor to water or steam valve.

- Q100 Linkage: Connects Modutrol IV Motor to butterfly valve.
- 221455A Motor Crank Arm: Infinitely adjustable crank arm; can rotate through the downward position and clear the base of motor without requiring the use of an adapter bracket. Approximately 0.75 in. [19 mm] shorter than the 4074ELY Crank Arm.
- 7617ADW Motor Crank Arm: Can rotate through the downward position and clear the base of the motor without requiring the use of an adapter bracket. Approximately 0.75 in. [19 mm] shorter than the 7616BR Crank Arm.
- Transformers: Mounted internally; provide 24 Vac power to the motor:
 - 198162EA: 120 Vac, 50/60 Hz.
 - 198162GA: 220 Vac, 50/60 Hz.
 - 198162AA: 120/208/240 Vac, 50/60 Hz.
- 4074ERU Weatherproofing Kit: Provides NEMA 3 rating when Modutrol IV Motor is mounted in other than upright position.

Installation

WHEN INSTALLING THIS PRODUCT...

1. Read these instructions carefully. Failure to follow them could damage the product or cause a hazardous condition.
2. Check the ratings and description given on the product to make sure the product is suitable for your application.
3. Installer must be a trained, experienced service technician.
4. After installation is complete, check out product operation as provided in these instructions.



CAUTION

1. Disconnect power before installation to prevent electrical shock or equipment damage.
2. To prevent damage to the motor, never turn the motor shaft by hand or with a wrench.
3. Always conduct a thorough checkout when installation is complete.

LOCATION

Install the Modutrol IV Motor in any location except where acid fumes or other deteriorating vapors might attack the metal parts, or in atmospheres of escaping gas or explosive vapors. Motors are rated for ambient temperatures between -40°F and $+150^{\circ}\text{F}$ [-40°C and $+66^{\circ}\text{C}$].

In excessive salt environments, mounting base and screws should be zinc or cadmium plate, not stainless steel or brass. Use the 220738A Adapter Bracket for mounting on these surfaces.

Allow enough clearance for installing accessories and servicing the motor when selecting a location (see Fig. 1). If located outdoors, mount the motor upright and use liquid-tight conduit connectors and wiring box to provide NEMA 3 weather protection. If mounted outdoors in a position other than upright, install the 4074ERU Weatherproofing Kit and liquid-tight conduit connectors to provide NEMA 3 weather protection.

MOUNTING

Always mount the motor with the shaft in a horizontal position. Mounting flanges extending from the bottom of the motor housing are drilled for 1/4 in. [6 mm] machine screws or bolts.

The Modutrol IV Motors are shipped in the closed position. The closed position is the limit of counterclockwise rotation as viewed from the power end of the motor. See Fig. 2.

ADAPTER BRACKET

The 220738A Adapter Bracket, positioned between the motor and the equipment, raises the motor shaft height by 0.75 in. [19 mm] to match that of the former Modutrol

Motor. This is required on all valve linkage applications (except the Q5001), Q607 External Auxiliary Switch applications, and on some damper linkage applications (either to provide clearance for the crank arm to rotate through the downward position, or to allow the damper linkage to reach the motor shaft).

To mount the motor with the bracket:

1. Mount the bracket to the equipment with existing or standard bolts.
2. Mount the motor to the bracket using the bolts provided. See Fig. 3.

Fig. 2—Motor shaft position at limit of rotation as viewed from the power end of the motor.

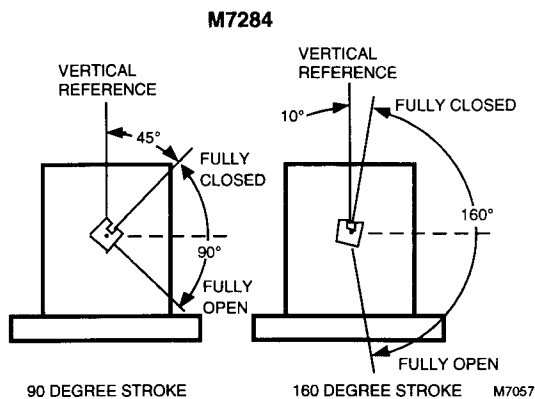

For valve linkage applications other than the Q5001, first mount the bracket to the linkage. The bracket then provides a convenient base on which the motor can be positioned. After the motor shaft is aligned with the linkage, attach the motor to the bracket with the four bolts provided. For the M7284, put the bolts through the outer set of back slots of the motor flange and into the threaded holes of the bracket. See Fig. 4.

LINKAGES

The 220738A Adapter Bracket (packed with the motor) is optional for many damper applications. Use the bracket in damper applications requiring the crank arm to rotate through the bottom plane of the motor. If you do not use the bracket, you will have to adjust the damper linkage to the new shaft location.

The 220738A Adapter Bracket must be used with the Q100, Q601 and Q618 Valve Linkages in all valve applications. The 220738A Adapter bracket is not required to be used with the Q5001 Valve Linkage. See Fig. 4.

The motor is supplied without a crank arm. The motor crank arm is included in the Q605 Linkage or may be ordered separately. (See Accessories.)

Fig. 3—Mounting the motor with an adapter bracket.

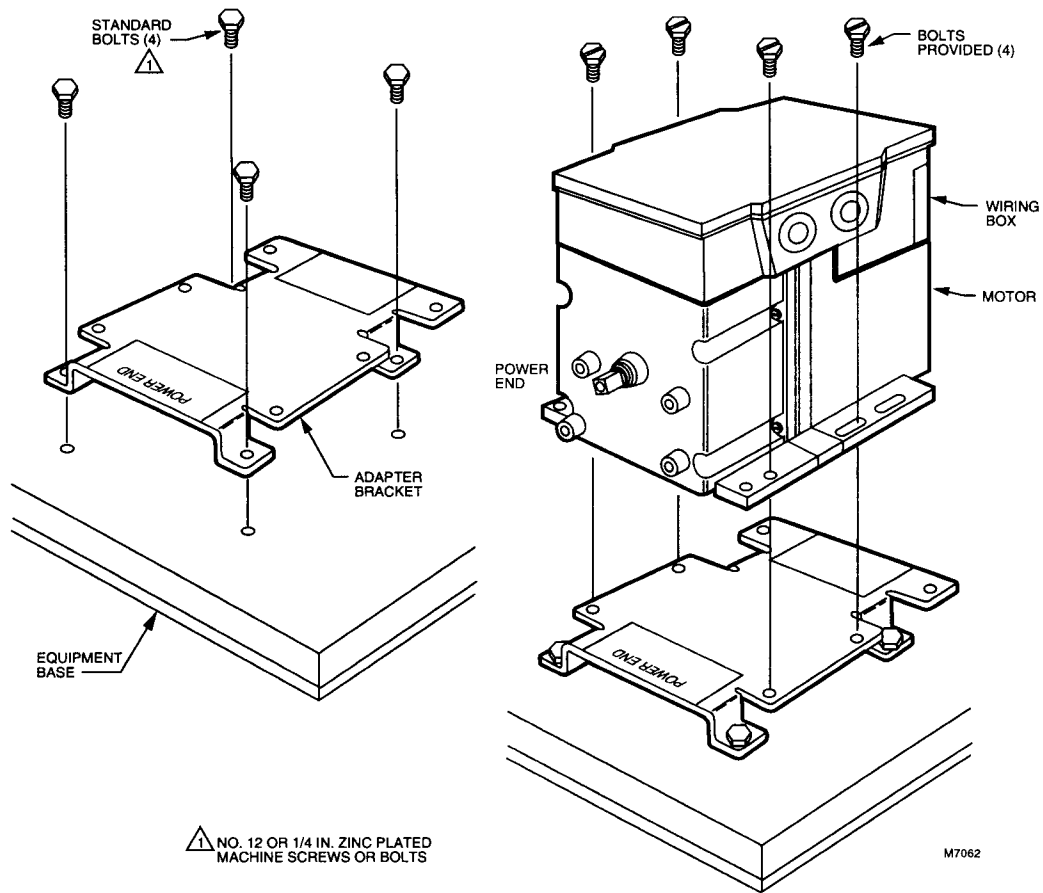
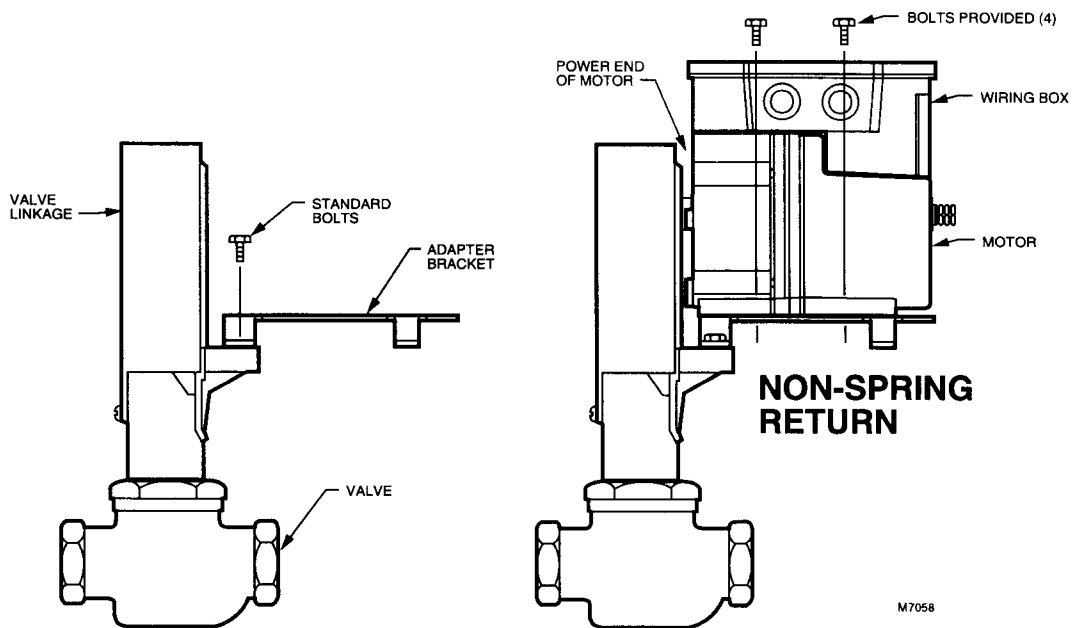

Fig. 4—Mounting Modutrol IV Motor on Q618 Valve Linkage.



For detailed instructions on the assembly of specific linkages, refer to the instructions packed with the linkage. In general, check the following points of operation when installing a motor and linkage:

1. Linkages for valves and louver-type dampers should be adjusted so that the damper or valve moves only through the maximum required distance while the motor moves through its full stroke.
2. With modulating control, maximum damper opening should be no more than 60 degrees. Little additional airflow is provided beyond this point.
3. The motor must be stopped at the end of its stroke by its internal limit switch and must not be stalled by the damper or valve. The motor will be damaged if it is not permitted to complete its full stroke.
4. Do not exceed the load and torque ratings in any application.
5. Do not turn the motor shaft manually or with a wrench, because this will damage the motor.

WIRING

Disconnect power supply before beginning wiring to prevent electrical shock or equipment damage. All wiring must comply with applicable local codes, ordinances, and regulations.

Make sure that the voltage and frequency stamped on the motor correspond to the characteristics of the power supply. If several motors are to be connected in parallel, make sure that the power supply VA rating is large enough to provide power to all the motors to be used without overloading. An integral transformer is used to supply 24 Vac power to the motor. Make sure that the power requirements stamped on the motor correspond to the characteristics of the power supply.

The motor terminals are quick-connects located on top of the printed circuit wiring board inside the wiring compartment. Gain access to the wiring compartment by removing the four screws on the top of the wiring box and lifting off the cover. See Fig. 5A for 4 to 20 mA wiring and Fig. 5B for Series 60 wiring. See Fig. 6 for the internal schematic. Fig. 7 shows connections for typical system applications.

Fig. 5—Terminals and adjustments.

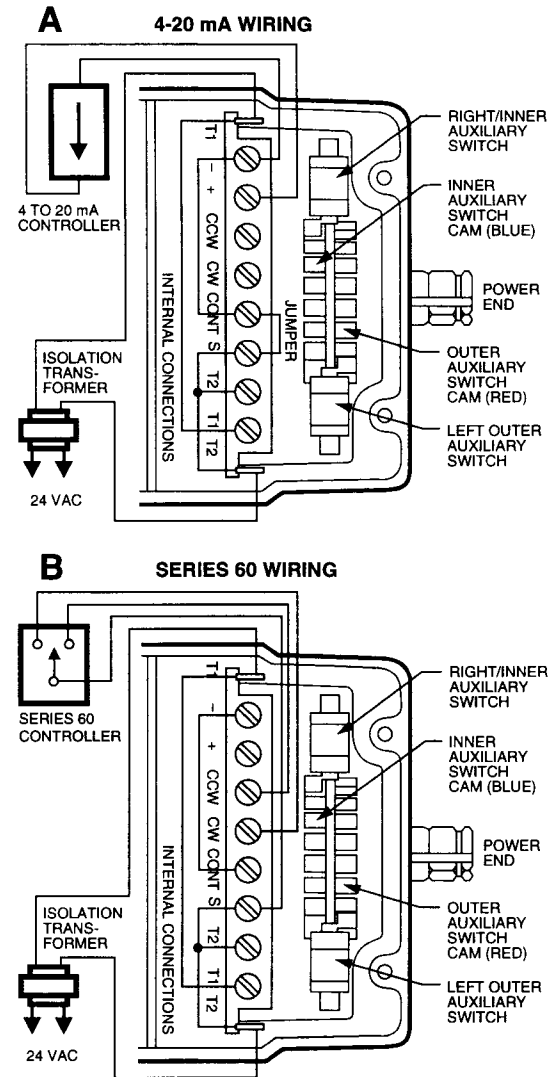

NOTE: FEATURES AVAILABLE ON SOME MODELS ONLY. M7063

Fig. 6—Internal schematic of Series 72 Motors.

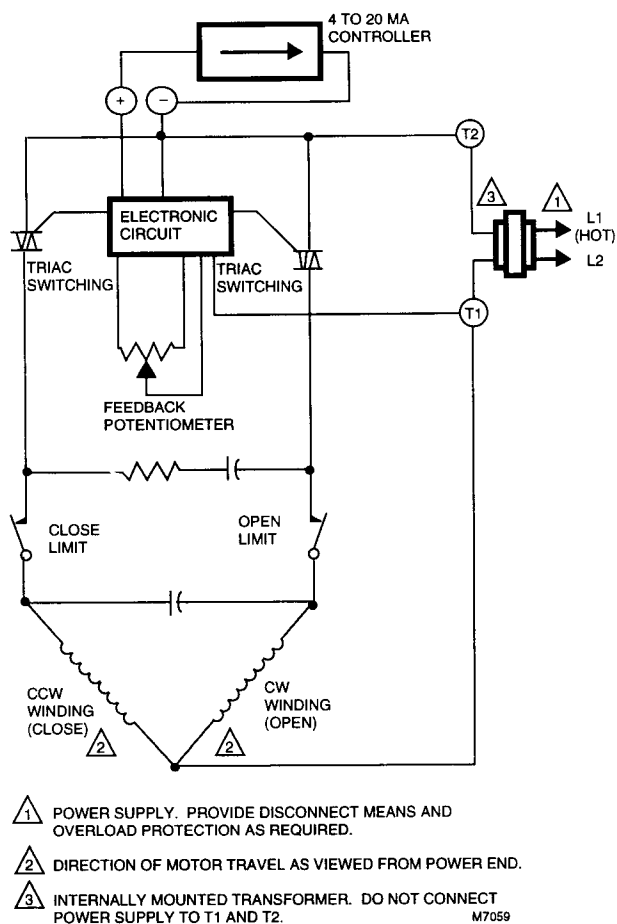

When used with liquid-tight conduit connectors, the wiring box provides NEMA 3 weather resistance for the motor when mounted in the upright position. The wiring

Fig. 7—Typical system wiring.

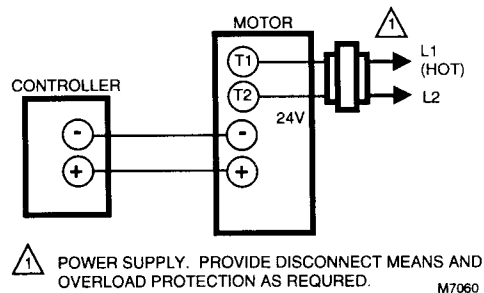



box, standard with replacement motors, also provides knock-outs for wiring conduits and encloses terminals. The wiring box is required for housing an internal transformer or internal auxiliary switches.

Wire the motor as follows:

1. Remove the wiring box cover by removing the four screws holding the cover to the motor.
2. Wire motor to system using quick-connect terminals in wiring box.
3. Replace wiring box cover.

AUXILIARY SWITCH

The auxiliary switches are actuated by adjustable cams. These cams can be set to actuate the switches at any angle within the stroke of the motor. Switch differentials of 1° or 10° can also be selected.

Motors with factory added auxiliary switches are shipped in the closed position (fully counterclockwise , as viewed from the power end of the motor) with auxiliary cams set to actuate switches 30° from the closed position and to provide 1° differential. With the motor in the closed (fully counterclockwise ) position, the auxiliary switch breaks contacts R-B. See Fig. 10 for auxiliary switch wiring.

Settings and Adjustments

Fig. 8 shows the slide switches, S1 and S2, and the potentiometers VR1, VR2, VR3, and VR4. Switches S1 and S2 and potentiometer VR4 are present only on the M7284Q Modutrol IV Motors. A basic description of the switches and potentiometers follows:

S1: In Zero Offset (down) position, VR4 is connected and the zero point is calibrated to -3.6 mA. Zero position may be adjusted from -12 mA to +12 mA. In the Zero (up) position, VR4 is disabled. This allows calibration of VR1 and VR2, and operation is in the fixed zero mode.

S2: In Direct (down) position, motor drives clockwise  with increasing signal (electrically normally

closed). In Reverse (up) position, motor drives counterclockwise  with increasing signal (electrically normally open).

Fig. 8—Settings and adjustments.



M7061

NOTE: Reverse action also changes zero position to fully clockwise on minimum input signal.

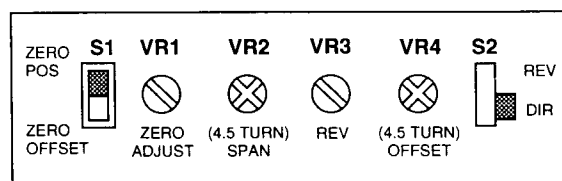
NOTE: Switches S1 and S2 and potentiometer VR4 are only on the M7284Q Modutrol IV Motor.

VR1 (Zero Adjust) is factory calibrated and provides a finer adjustment for "leave closed," which is the input that will just drive the motor from the fully closed position (factory calibrated at 4.4 mA).

VR2 (Span) is factory calibrated on the M7284C. VR2 adjusts the motor response to travel full stroke through the selected input signal span. The M7284C is factory calibrated to 16 mA. The M7284Q is adjustable from 8.0 to 32.0 mA.

VR3 (Rev) adjusts the amount of signal change required to move the motor one step on the opposite direction (from the most recent movement). Fully clockwise is maximum signal change to reverse the motor. Adjusting to a smaller value may cause instability as a signal fluctuation might reposition the motor. The range of adjustment for VR3 is 0.16 mA minimum to 0.80 mA maximum.

VR4 (Offset) is available only on M7284Q models and is active only when S1 is in the Zero Offset position. VR4 allows a wider adjustment of zero position than is available with VR1 and allows any setting of zero from -12 mA to +12 mA.

AUXILIARY SWITCH SETTING PROCEDURE

(See Fig. 9.)



CAUTION



1. Live circuits are exposed during the auxiliary switch adjustment procedure. Always turn off the power before adjusting switch cams.
2. Do not turn motor shaft by hand or with a wrench as damage to the motor can result.

1. Remove the top cover from the wiring box to gain access to motor terminals and auxiliary switch cams.

2. Disconnect the controller from the motor and connect a current source to the positive (+) and negative (-) terminals.

3. Increase or decrease the current to drive the motor to the position where auxiliary equipment is to be switched.

4. For a switch differential of 1°, check the continuity of auxiliary switch R-B contacts and rotate the cam as follows:



- a. If contacts are open, rotate cam clockwise  until R-B contacts close.
- b. If contacts are closed, rotate cam counterclockwise  until R-B contacts open.

5. For switch differential of 10°, rotate cam approximately 180° so that slow-rise portion of cam actuates

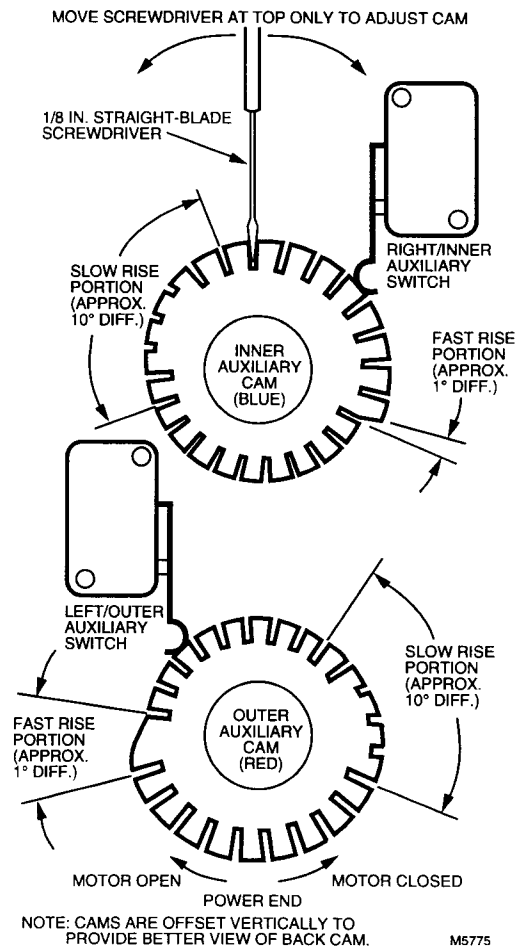
Fig. 9—Auxiliary switch and adjustable cams.



switch, then check continuity of auxiliary R-B contacts and rotate cam as follows:

- a. If contacts are open, rotate cam counterclockwise  until R-B contacts close.
- b. If contacts are closed, rotate cam clockwise  until R-B contacts open.
- c. Make final adjustment in the proper direction to obtain contact make or break at the desired position.

6. Check for proper differential and switching of auxiliary equipment by driving motor through full stroke in both directions.

7. Disconnect power, remove current source, reconnect controller and replace the top cover on the motor wiring box.

8. Restore power to the equipment.

NOTE: If differential is changed from 1° to 10°, the switching action is reversed. Switch contacts R-B make and R-W break on a counterclockwise  (closed) rotation.

Operation and Checkout

OPERATION

4-20 mA Operation

The motor feedback potentiometer and control current input circuit form a bridge circuit. As long as the final control element remains at the position proportional to the input current from the controller, the circuit is balanced, and the motor does not run. When the value of the controlled medium changes, the current from the controller changes, and unbalance is amplified to energize the Triac switching to run the motor in the proper direction to correct the change in the temperature or the pressure. The motor turns the feedback potentiometer to rebalance the circuit and stop the motor.

Series 60 Operation

When wired as a Series 60 motor (see Fig. 5B), the M7284 acts as a three-wire floating control motor. These motors are used for standard Series 60 operation (drive open, hold drive closed).

When the controller R-B contacts make, the motor will run open. The motor will continue to run until the limit of rotation is reached and the limit switch opens, or until the controller opens the R-B contact.

CHECKOUT

After installation and linkage adjustment, operate the motor through the controller. Make sure that:

- The motor properly operates the damper or valve.
- The motor responds properly as the input is varied.
- The auxiliary switch, if used, operates at the desired point of motor rotation.

Inspect the motor, linkage, and valve or damper to see that all mechanical connections are correct and secure. In damper installations, do not extend the pushrod more than a few inches past the ball joints. Check to see that there is adequate clearance for the linkage to move through its stroke without binding or striking other objects. See the controller or system instructions for additional checkout procedures.

Honeywell

Helping You Control Your World



QUALITY IS KEY

Home and Building Control

Honeywell Inc.
1985 Douglas Drive North
Golden Valley, MN 55422

Home and Building Control

Honeywell Limited—Honeywell Limitée
740 Ellesmere Road
Scarborough, Ontario
M1P 2V9

Printed in U.S.A.